



Calculation of RF Exposure Compliance Boundaries at a Radio Base Station Rooftop Site



Site Name: Houtbay Senior Secondary

Site Address:
Marlin Crescent
Houtbay
Cape Town
South Africa

Report Number: P00-2011-02

Site report date: 23 August 2011

Date of Report: 23 August 2011

Title: Calculation of RF Exposure Compliance Boundaries at a Radio Base Station Rooftop Site

Site Location: Marlin Crescent, Hout Bay, Cape Town, South Africa

Site Coordinates (at Antennas): 34.053104 S, 18.343467 E



Google Earth Hyperlink:

Houtbay Senior Secondary.kmz

Evaluation Laboratory:

EMSS Consulting
3 Meson Street
Tegnopark
Stellenbosch
South Africa

Company/Client:

Various Cellular Operators
South Africa

Evaluation performed by:

Fritz Grobbelaar & Wessel van Brakel

Date of Evaluation:

23 August 2011

Document History:

Revision	Issue Date	Report Numbers	Changes made
A	19 July 2011	P00-2011-01	Initial report
B	23 August 2011	P00-2011-02	Used updated procedure with latest IXUS upgrade

Assessor:

Fritz Grobbelaar (EMSS Consulting)

Quality Assurance:

Wessel van Brakel (EMSS Consulting)
Frans Meyer (EMSS Consulting)

1. Executive Summary

The purpose of this evaluation is to determine the RF exposure compliance boundaries at an operational roof-top macro base station site at which additional transmitters (and associated antennas) are planned. The goal of the compliance boundary assessment is to determine the area around the base station antennas where the exposure limits will not be exceeded once the planned transmitters are switched on. The assessment involved a desktop simulation, and specifically using the ray tracing computational assessment method as detailed in the IEC 62232^[1] standard as was implemented in the commercially available code IXUS^[2], to determine the compliance boundary. The maximum values were compared against the ICNIRP (International Commission on Non Ionizing Radiation Protection) occupational and general public guidelines^{[3][4]}.

An initial visual inspection of the site showed no significant RF field contribution from RF sources other than the cellular antennas.

Full uncertainty analyses were performed for the ray tracing assessment method, as required by the IEC 62232 standard. A 95% Confidence Interval (CI) is used in the results and related control boundaries presented, ensuring conservative results for 97.5% of all cases.

The results obtained are presented graphically to clearly show the position of accessible exclusion zones at the site, at the 95% confidence interval associated with the occupational and general public guidelines. These can be used to implement the necessary signage and access control measures at the site.

2. Evaluation Overview (see clause 6.1 of IEC 62232)

2.1 Site Operator Information

The test results presented in this report define 95% CI ICNIRP compliance boundaries for the combined contribution of the three network operators currently present at the site (Operator A, Operator B and Operator C) as well as the proposed new service provider (Operator D) that will go live in due course. The site is situated on the Houtbay Senior Secondary School building in Cape Town.

The base station of Operator A consists of three Kathrein 742266 antennas. The downlink transmission power is 100 watts for the GSM900 band and 120 watts for the UMTS2100 band. The base station of Operator B consists of two Kathrein 742241 antennas. The downlink transmission power is 80 watts for each of the GSM900 and DCS1800 bands and 40 watts for the UMTS2100 band. The base station of Operator C consists of two Kathrein 739495 antennas and one Kathrein 739491 antenna. The downlink transmission for the DCS1800 band is 80 watts. The **planned** base station for Operator D consists of two Amphenol Antel C-BXA80061-8-M antennas. The downlink transmission for the 850MHz band of Operator D will be 40 watts. The Operator D antennas were installed, but not connected to the RBS (Radio Base Station) at the time of this evaluation.

Table 2.1: Operator technology information

Operator	Technology
Operator A	GSM900, UMTS2100
Operator B	GSM900, DCS1800, UMTS2100
Operator C	DCS1800
Operator D*	WCDMA850

*Note that the planned transmitter information for Operator D was used since Operator D was not commissioned at the time of evaluation

2.2 Site Environment

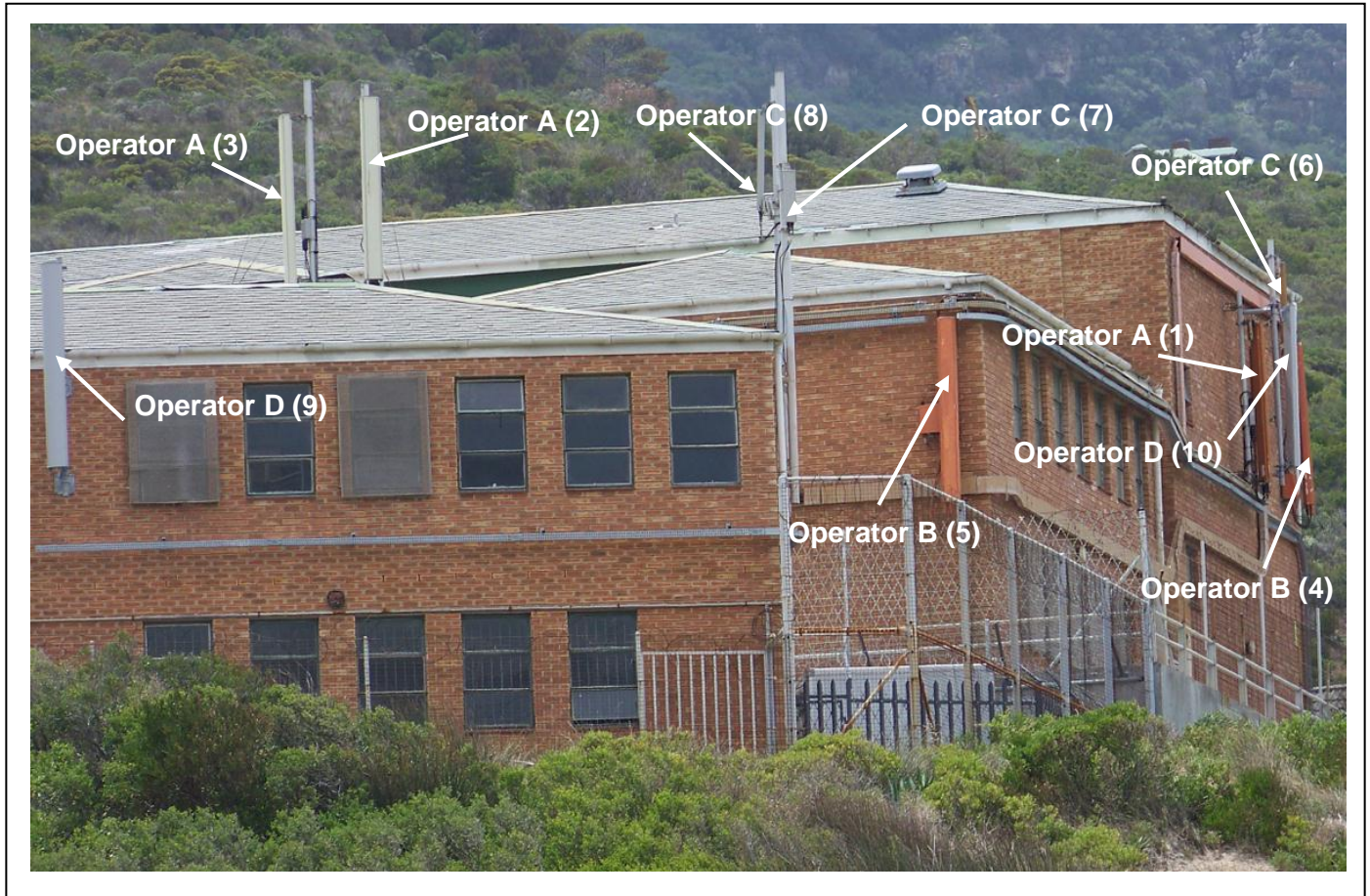

Figure 1: Photograph of the antennas at the site under evaluation

As shown in Figure 1, two antennas (2 & 3) from Operator A and two antennas (7 & 8) from Operator C are mounted low above a roof level. Antennas 2, 3 and 8 are mounted so that their main lobes are in the direction of the nearby rooftop. The remaining antennas on site are mounted at various positions on the walls around the building.

2.3 Exposure safety limits

The guidelines on limiting exposure, published by ICNIRP^{[3] [4]}, are used in this report. The ICNIRP guidelines consist of two tiers, one for occupational exposure and the other for the general public.

3. Evaluation Plan

3.1 Pre-evaluation review

3.1.1 Determine Evaluation Purpose (Clause 5.2 of IEC 62232)

Purpose	To establish compliance boundaries at certain points surrounding the shared RBS site where the ICNIRP reference guidelines are met with a 95% Confidence Interval.
----------------	--

3.1.2 Determine RBS category (Annex 2.2 of IEC 62232)

Complex RBS Category	This category is selected since the evaluation needs to consider more than one radiating RBS antenna from multiple operators.
-----------------------------	---

3.1.3 Information availability (Annex 2.3 of IEC 62232)

The detailed antennas and transmitter information are listed in Annex A.

3.1.4 Establish if ambient fields are to be considered

A visual inspection was performed and no unknown antennas were observed on or in close vicinity to the site. It can thus be concluded with relative certainty that any RF exposure contributions for other sources not part of the RBS would be negligible compared to the field values from the RBS antennas.

3.2 Select Evaluation method

Quite a number of the antennas at site are close to each other and this will result in complex overlapping exclusion zones, which can accurately and efficiently be determined using the ray-tracing assessment method. The ray-tracing (synthetic model) advanced computational method (IEC 62232, Clause 6.3.3.1) will be employed since it is the simplest method to achieve the evaluation purpose. The ray-tracing computational method can be used in this case since the characteristics of all sources are well defined. The frequencies, transmitter power, antenna characteristics, height of antenna, etc are all known.

The evaluation method chosen is appropriate for the required solution and the assessor has suitable computational resources to do the evaluation with access to the IXUS Modeller which is an implementation of the ray-tracing (synthetic model) computational method.

3.2.1 Establish the evaluation locations required

Evaluations are required everywhere on and just above the roof-top, ground level and inside the buildings to determine the ICNIRP public and occupational exclusion zones. The evaluations in source regions II and III were performed and extrapolated to source region I. Since the occupational guidelines were exceeded in the entire source region I, the occupational guideline boundary lies outside that region. It is thus not necessary to evaluate further in that region.

4. Performing the Evaluation:

The Advanced Computational Methods: Ray Tracing (See Clause 6.3.3.1 of IEC 62232)

The IXUS software suite implements the ray-tracing algorithm as detailed in Clause 6.3.3.1 of the IEC 62233 standard. The IXUS software has been validated against pre-calculated examples^[5] as required by the IEC 62232 standard (see Clause 6.3.3.1.3 and Annex H.3 of the IEC 62232 standard).

To setup the computations, a CAD model of the buildings in the vicinity of the antennas at the RBS is drawn on a desktop computer. The purpose of this is to provide context to the exclusion zones and associated compliance boundaries that will be obtained from the computer simulations at this rooftop site. IXUS also requires that each of the antennas be positioned in the CAD model and the antenna and transmitter details must be entered. The building dimensions and antenna positions can be obtained from blue-prints or site plan documentation. For this specific site such documentation was not available and a surveying team was sent to site to capture the required dimensions and obtain the necessary information (building dimensions, photographs, detail of site equipment, etc.). The CAD model was then drawn from the dimension details and the supporting information was used for quality assurance by office personnel. Figure 2 and Figure 3 show the CAD model with antenna positions for the RBS site under investigation.

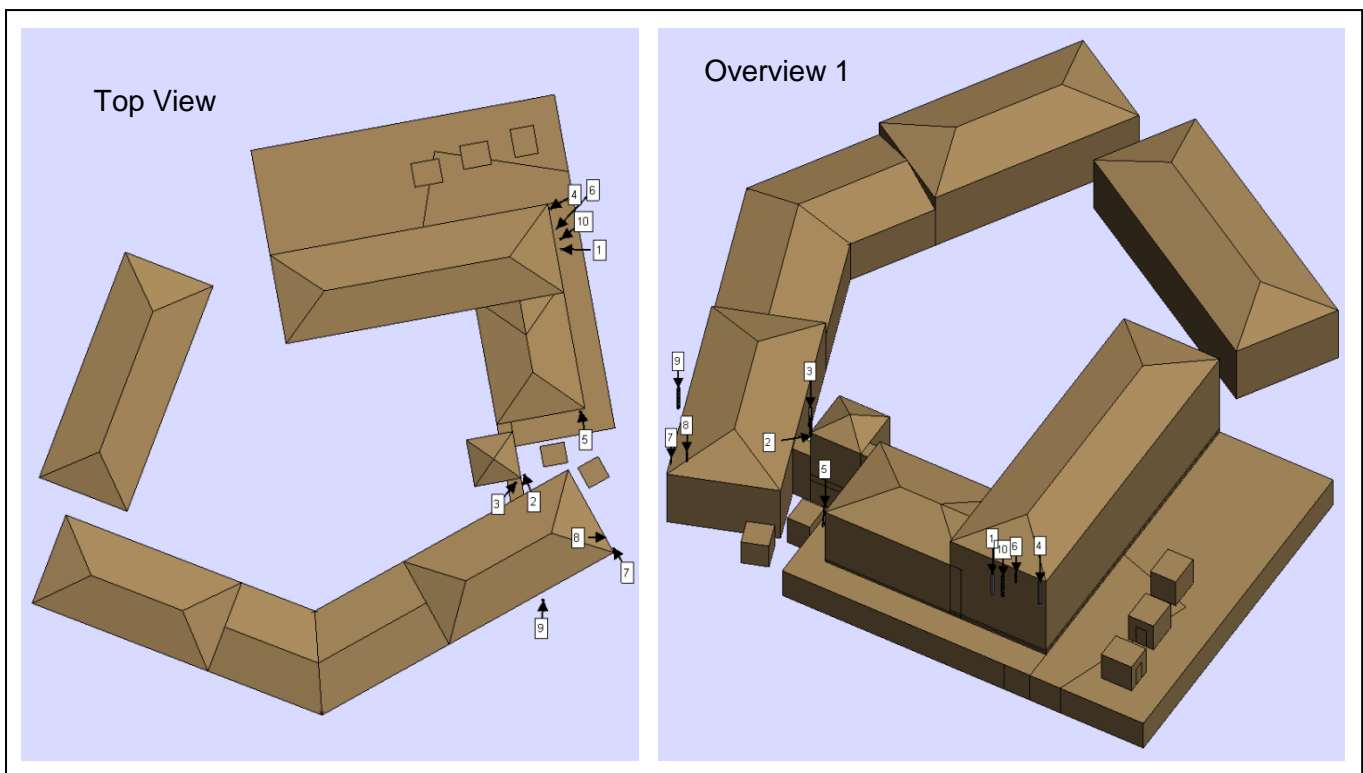

Figure 2: CAD of the site under evaluation

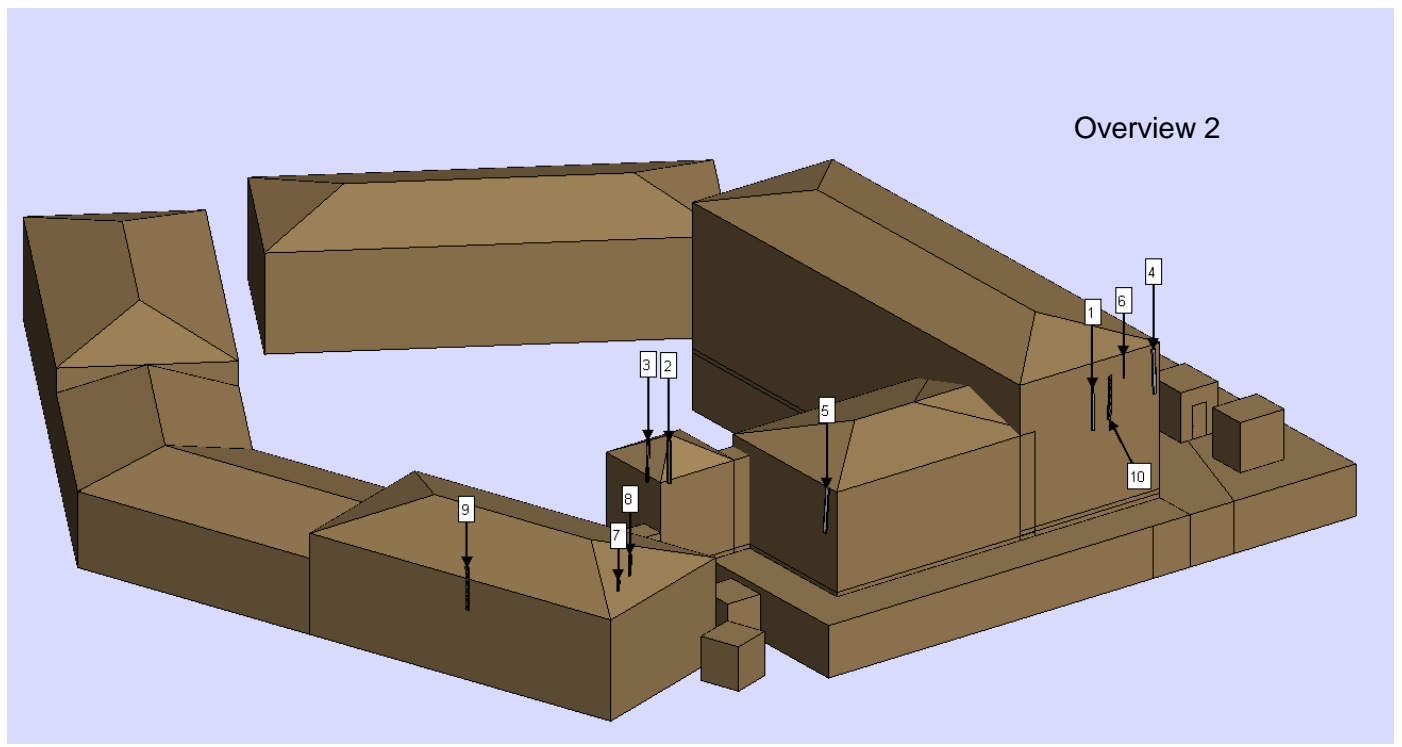

Figure 3: CAD of the site under evaluation (cont.)

4.1 Uncertainty Analysis

The IXUS software, by default, gives field results for best estimates without any cable or antenna losses. In order to ensure an upper 95% CI (i.e., a conservative assessment), an uncertainty analysis should first be performed (IEC 62232, Clause 7). The expanded uncertainty can then be used to adjust the field levels to ensure the results comply with the upper 95% CI for the analysis at hand. From the IXUS software documentation^[6], a detailed uncertainty analysis is available (see Annex B) and by activating the uncertainty option in IXUS the field levels are automatically adjusted to ensure the results comply with the selected % CI (in this case the upper 95% CI was selected).

Also, for this case study, the feed cable loss for the different frequencies of each antenna was calculated (see Annex C) and the results were used as input for the frequency band information used in each antenna in IXUS. So in this example the cable losses are known and used in IXUS, and does not form part of the uncertainty analysis.

4.2 Field Computations

Once the resulting power values and losses are populated in the IXUS software, the field values can be computed. The evaluation results are presented in Section 5 below.

5. Evaluation Results

IXUS computations were performed for all the operational transmitters / antennas as well as all the planned transmitters / antennas on the site. The area where the combined field values from all services exceeds the ICNIRP public- and occupational guidelines are shown in Figure 4. The yellow zones indicate the volumes where the general public guidelines are exceeded and the red zones indicate the volumes where the occupational guidelines are exceeded.

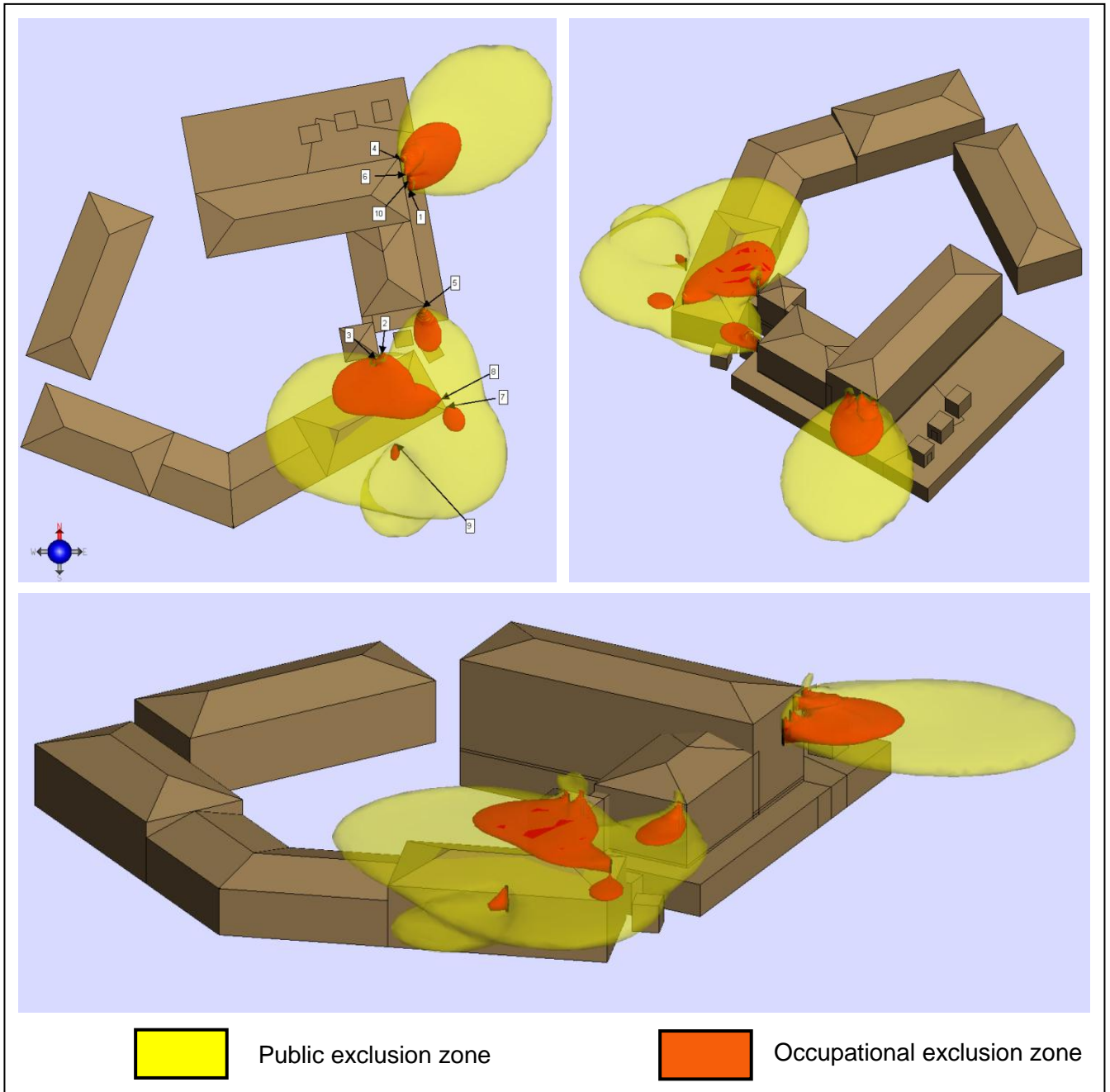

Figure 4: CAD of the site under evaluation after performing the field computations

The projection feature of IXUS can show where the guidelines are exceeded, within a volume of a set limit, above all surfaces within the CAD. Figure 5 shows the results of all volumes 2m or less above the roof areas in which the ICNIRP guidelines are exceeded. These are thus the only surfaces on the roof, accessible to a person, where the ICNIRP guidelines could be exceeded. The edges of the yellow and red zones in Figure 5 thus represent the compliance boundaries at the site. From the uncertainty analysis performed and used as part of the IXUS calculator (Section 4.1), there is a 97.5% certainty (the upper 95% Confidence Interval) that exposure beyond these boundaries will be less than the ICNIRP limits.

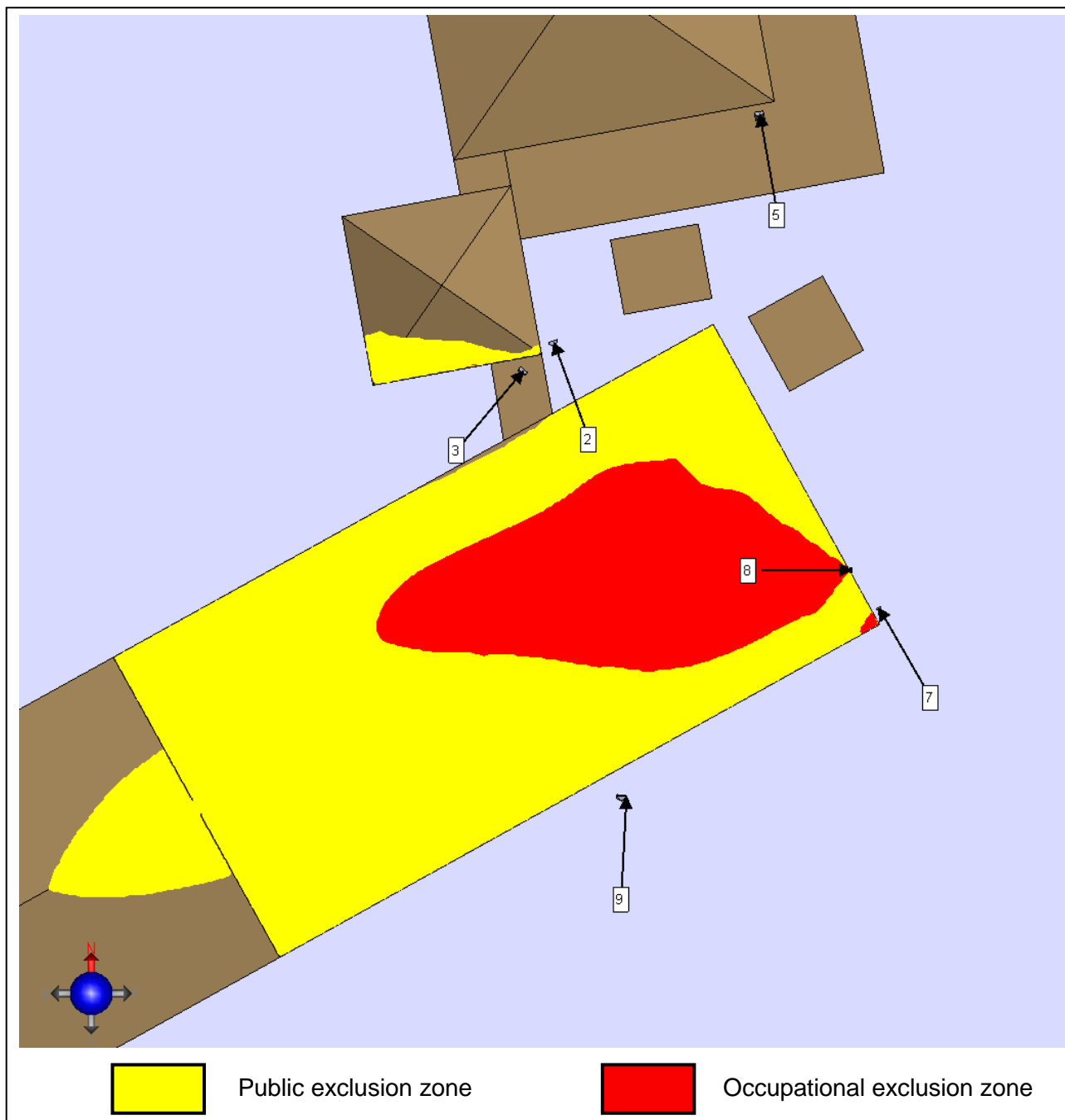

Figure 5: CAD of the site under evaluation after performing the simulation

6. Interpretation of Results

For a site to comply with the ICNIRP guidelines, the necessary access control measures (signage or barricades) need to be in place to ensure that the general public and RF workers do not enter into areas where the total combined field values from all the services at the site exceed the ICNIRP guidelines.

The areas at the rooftop site under investigation where the ICNIRP guidelines could be exceeded were calculated using the Advanced Computational Method, Ray Tracing, as detailed in the IEC 62232 standard, using the implementation of this method in IXUS. A full uncertainty analysis of the method was performed (see Annex B), and the results were accordingly adjusted in the IXUS Modeller to ensure an upper (conservative) 95% CI. These graphical representations of the results together with the site CAD layout presented in this report can be used to implement the necessary administrative controls. These measures could include installation of appropriate signage, access control, and/or re-engineering in order for the site to comply with the guidelines.

Annex A: Detail Antenna and Transmitter Information

The antenna parameters are given in this section. An antenna with an azimuth direction of 0° radiates directly towards true North. A positive electrical or mechanical tilt means that the tilt is directed downward.

Antenna 1

Owner	Operator A
Manufacturer	Kathrein 742266
Antenna gain	The gain of the antenna is included in the IXUS model for the antenna after the Manufacturer and Model is given as input
Beam width	The beam width of the antenna is included in the IXUS model for the antenna after the Manufacturer and Model is given as input
Orientation	Coordinates of base: 19.69m North; 45.38m East; Height = 8.75m
Mechanical Tilt	-1°
Azimuth direction	40°
Dimensions	The dimensions of the antenna is included in the IXUS model for the antenna after the Manufacturer and Model is given as input
Technology (Frequency bands used)	GSM900 and UMTS2100
Transmit Power	GSM900: 2 ports of 50W each; UMTS2100: 2 ports of 60W each
Electrical tilt	GSM900: 7°; UMTS2100: 3°

Antenna 2

Owner	Operator A
Manufacturer	Kathrein 742266
Antenna gain	The gain of the antenna is included in the IXUS model for the antenna after the Manufacturer and Model is given as input
Beam width	The beam width of the antenna is included in the IXUS model for the antenna after the Manufacturer and Model is given as input
Orientation	Coordinates of base: 4.18m South; 41.40m East; Height = 8.73m
Mechanical Tilt	0°
Azimuth direction	160°
Dimensions	The dimensions of the antenna is included in the IXUS model for the antenna after the Manufacturer and Model is given as input
Technology (Frequency bands used)	GSM900 and UMTS2100
Transmit Power	GSM900: 2 ports of 50W each; UMTS2100: 2 ports of 60W each
Electrical tilt	GSM900: 7°; UMTS2100: 3°

Antenna 3

Owner	Operator A
Manufacturer	Kathrein 742266
Antenna gain	The gain of the antenna is included in the IXUS model for the antenna after the Manufacturer and Model is given as input
Beam width	The beam width of the antenna is included in the IXUS model for the antenna after the Manufacturer and Model is given as input

Orientation	Coordinates of base: 5.04m South; 40.47m East; Height = 8.6m
Mechanical Tilt	-1°
Azimuth Direction	220°
Dimensions	The dimensions of the antenna is included in the IXUS model for the antenna after the Manufacturer and Model is given as input
Technology (Frequency bands used)	GSM900 and UMTS2100
Transmit Power	GSM900: 2 ports of 50W each; UMTS2100: 2 ports of 60W each
Electrical tilt	GSM900: 7°; UMTS2100: 3°

Antenna 4

Owner	Operator B
Manufacturer	Kathrein 742241
Antenna gain	The gain of the antenna is included in the IXUS model for the antenna after the Manufacturer and Model is given as input
Beam width	The beam width of the antenna is included in the IXUS model for the antenna after the Manufacturer and Model is given as input
Orientation	Coordinates of base: 24m North; 44.23m East; Height = 9.62m
Mechanical Tilt	-2°
Azimuth Direction	60°
Dimensions	The dimensions of the antenna is included in the IXUS model for the antenna after the Manufacturer and Model is given as input
Technology (Frequency bands used)	GSM900, DCS1800 and UMTS2100
Transmit Power	GSM900: 2 ports of 40W each; DCS1800: 2 ports of 40W each; UMTS2100: 2 ports of 20W each
Electrical tilt	GSM900: 7°; DCS1800: 5°; UMTS2100: 3°

Antenna 5

Owner	Operator B
Manufacturer	Kathrein 742241
Antenna gain	The gain of the antenna is included in the IXUS model for the antenna after the Manufacturer and Model is given as input
Beam width	The beam width of the antenna is included in the IXUS model for the antenna after the Manufacturer and Model is given as input
Orientation	Coordinates of base: 2.13m North; 47.43m East; Height = 6.93m
Mechanical Tilt	-4°
Azimuth Direction	170°
Dimensions	The dimensions of the antenna is included in the IXUS model for the antenna after the Manufacturer and Model is given as input
Technology (Frequency bands used)	GSM900, DCS1800 and UMTS2100
Transmit Power	GSM900: 2 ports of 40W each; DCS1800: 2 ports of 40W each; UMTS2100: 2 ports of 20W each
Electrical tilt	GSM900: 7°; DCS1800: 5°; UMTS2100: 3°

Antenna 6

Owner	Operator C
Manufacturer	Kathrein 739495

Antenna gain	The gain of the antenna is included in the IXUS model for the antenna after the Manufacturer and Model is given as input
Beam width	The beam width of the antenna is included in the IXUS model for the antenna after the Manufacturer and Model is given as input
Orientation	Coordinates of base: 21.82 North; 44.81 East; Height = 11.21m
Mechanical Tilt	0°
Azimuth Direction	30°
Dimensions	The dimensions of the antenna is included in the IXUS model for the antenna after the Manufacturer and Model is given as input
Technology (Frequency bands used)	DCS1800
Transmit Power	DCS1800: 2 ports of 40W each
Electrical tilt	DCS1800: 2°

Antenna 7

Owner	Operator C
Manufacturer	Kathrein 739491
Antenna gain	The gain of the antenna is included in the IXUS model for the antenna after the Manufacturer and Model is given as input
Beam width	The beam width of the antenna is included in the IXUS model for the antenna after the Manufacturer and Model is given as input
Orientation	Coordinates of base: 11.92m South; 50.88m East; Height = 7.68
Mechanical Tilt	-1°
Azimuth Direction	150°
Dimensions	The dimensions of the antenna is included in the IXUS model for the antenna after the Manufacturer and Model is given as input
Technology (Frequency bands used)	DCS1800
Transmit Power	DCS1800: 2 ports of 40W each
Electrical tilt	DCS1800: 6°

Antenna 8

Owner	Operator C
Manufacturer	Kathrein 739495
Antenna gain	The gain of the antenna is included in the IXUS model for the antenna after the Manufacturer and Model is given as input
Beam width	The beam width of the antenna is included in the IXUS model for the antenna after the Manufacturer and Model is given as input
Orientation	Coordinates of base: 10.80m South; 50.04m East; Height = 8.03m
Mechanical Tilt	-2°
Azimuth Direction	270°
Dimensions	The dimensions of the antenna is included in the IXUS model for the antenna after the Manufacturer and Model is given as input
Technology (Frequency bands used)	DCS1800
Transmit Power	DCS1800: 2 ports of 40W each
Electrical tilt	DCS1800: 2°

Antenna 9

Owner	Operator D
Manufacturer	Amphenol Antel C-BXA-80065-8-M
Antenna gain	The gain of the antenna is included in the IXUS model for the antenna after the Manufacturer and Model is given as input
Beam width	The beam width of the antenna is included in the IXUS model for the antenna after the Manufacturer and Model is given as input
Orientation	Coordinates of base: 17.40m South; 43.38m East; Height = 4.61m
Mechanical Tilt	1°
Azimuth Direction	183°
Dimensions	The dimensions of the antenna is included in the IXUS model for the antenna after the Manufacturer and Model is given as input
Technology (Frequency bands used)	WCDMA850
Transmit Power	WCDMA850: 1 port of 40W each
Electrical tilt	WCDMA850: 0°

Antenna 10

Owner	Operator D
Manufacturer	Amphenol Antel C-BXA-80065-8-M
Antenna gain	The gain of the antenna is included in the IXUS model for the antenna after the Manufacturer and Model is given as input
Beam width	The beam width of the antenna is included in the IXUS model for the antenna after the Manufacturer and Model is given as input
Orientation	Coordinates of base: 20.74m North; 45.25m East; Height = 9.12m
Mechanical Tilt	1°
Azimuth Direction	53°
Dimensions	The dimensions of the antenna is included in the IXUS model for the antenna after the Manufacturer and Model is given as input
Technology (Frequency bands used)	WCDMA850
Transmit Power	WCDMA850: 1 port of 40W each
Electrical tilt	WCDMA850: 0°

Annex B: Detailed Uncertainty Analysis (Annex O of IEC 62232)

For this investigation study, the cable losses for each antenna are known and were taken into account when performing the simulations. The uncertainties presented in the IXUS software uncertainty analysis^[6] include a component for the cable losses, which was not used for this case. This annex presents the detail of how the uncertainty analysis was applied to determine a scaling factor which is multiplied with the antenna power to obtain a result which falls within the 95% CI. It is important to note that exact details of all the objects on the rooftop in the vicinity of the antennas are not known and scattering and reflections from such objects, including the roof (as a ground plane), is included in the uncertainty analysis under reflections and scatterings.

Table B1: Information used in IXUS Software Uncertainty Analysis^[6] :

Parameter Name	Brief Description	Uniform Uncertainty in output Power Density (dB)
Input Power	Transmitter power can vary	-2 to 2
Radiation Loss	Lossy components inside antennas cause radiation loss	-2.5 to 0
Reflection and Scattering	Scattering and reflections on top of buildings can create hotspots where E-fields add in-phase	-4.8 to 4.8
Near-field Model Uncertainty*	Simplicity of antenna models and the method for determining model parameters limit the accuracy of field predictions	-3 to 3
Far-field Model Uncertainty*	Method for determining model parameters limits the accuracy of field predictions	-1.2 to 1.2

*Note that the Near-field and Far-field Model Uncertainties are mutually exclusive

Table B2: Calculation of combined uncertainty:

Source of uncertainty	unit	prob. distrib. type	uncertainty or semi span <i>a</i>	divisor <i>d</i>	sens. coeff. <i>c_i</i>	standard uncertainty <i>u = a/d</i>	corr. fact <i>t</i>	<i>c²u²</i>
System								
Variation in the power of the RF transmitter from its nominal level	dB	Rectangular	2	K=√3	1	1.155	0	1.33
Antenna dissipation loss (the ratio of the total radiated power to the total input power)	dB	Rectangular	1.25	K=√3	1	0.722	-1.25	0.52
Technique Uncertainties								
Inherent uncertainties associated with the approximate numerical model used to represent the antenna in the near-field	dB	Rectangular	3	K=√3	1	1.732	0	3
Inherent uncertainties associated with the approximate numerical model used to represent the antenna in the far-field	dB	Rectangular	1.2	K=√3	1	0.693	0	0.48
Environmental Uncertainties								
Scattering from nearby objects and the ground	dB	Rectangular	4.8	K=√3	1	2.771	0	7.68
Combined correction factor, $t_c = \sum_{i=1}^N t_i$							-1.25	N/A
Combined Standard Uncertainties for Near-field $\sqrt{\sum_{i=1}^m c_i^2 u_i^2}$								3.54
Combined Standard Uncertainties for Far-field $\sqrt{\sum_{i=1}^m c_i^2 u_i^2}$								3.16

As the combined standard uncertainties in the near-field are larger than the standard uncertainties in the far field, this value is used as it results in a conservative simulation.

The standard deviation for the uncertainty in the near field expressed as dB is as follows:

$$\sigma = 3.54\text{dB}$$

The expanded uncertainty for the 95% CI is thus:

$$\begin{aligned} 1.96\sigma &= 1.96 \times 3.54 \\ &= 6.94\text{dB} \end{aligned}$$

This value is adjusted by the correction factor of -1.25 dB, which is added in order to find the value which will be added in IXUS to obtain the 95% CI.

$$\begin{aligned} \text{Uncertainty Analysis Scaling factor} &= 6.94 + (-1.25) \\ &= 5.69\text{dB} \end{aligned}$$

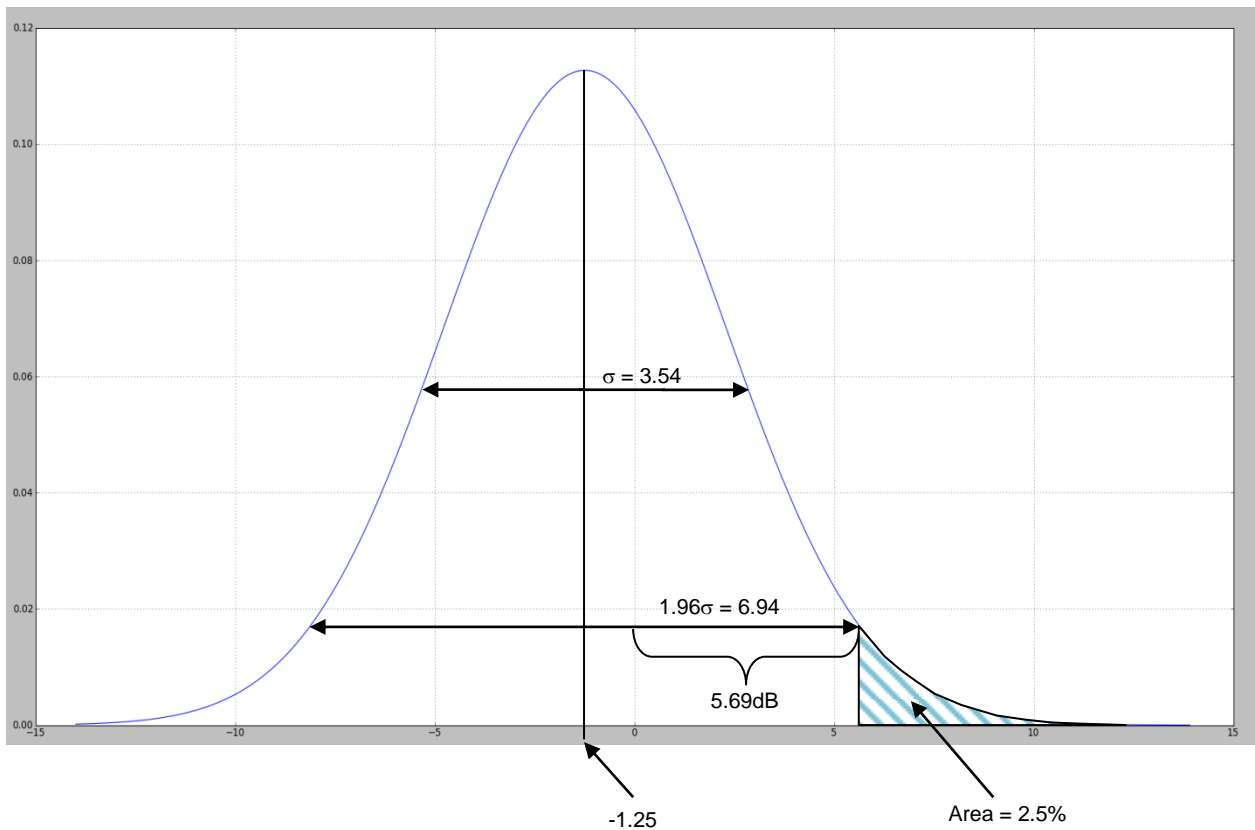

Annex C: IXUS Power Loss Calculations

The frequency band information in the IXUS software has a field for combined cable losses when the uncertainty option for cable losses is disabled. Below are the detail calculations of how the feed cable losses were calculated.

Antenna 1:

GSM900	Feeder losses (50m of 7/8")	3.53dB*50m/100m	1.765dB
	Fly Lead losses (5m of 1/2")	6.85dB*5m/100m	0.34dB
	Diplexer	0.15dB x2	0.3dB
	Surge arrestor		0.1dB
	Total GSM900 system loss		2.505dB
UMTS2100	Feeder losses (50m of 7/8")	5.98dB*50/100	2.99dB
	Fly Lead losses (5m of 1/2")	11.5dB*5m/100m	0.575dB
	Diplexer	0.15dB x2	0.3dB
	ASC		0.4dB
	Surge arrestor		0.1dB
	Total UMTS2100 system loss		4.365dB

Antenna 2:

GSM900	Feeder losses (15m of 7/8")	3.53dB*15m/100m	0.5295dB
	Fly Lead losses (5m of 1/2")	6.85dB*5m/100m	0.34dB
	Diplexer	0.15dB x2	0.3dB
	Surge arrestor		0.1dB
	Total GSM900 system loss		1.27dB
UMTS2100	Feeder losses (15m of 7/8")	5.98dB*15/100	0.897dB
	Fly Lead losses (5m of 1/2")	11.5dB*5m/100m	0.575dB
	Diplexer	0.15dB x2	0.3dB
	ASC		0.4dB
	Surge arrestor		0.1dB
	Total UMTS2100 system loss		2.272dB

Antenna 3:

GSM900	Feeder losses (18.5m of 7/8")	3.53dB*18.5m/100m	0.653dB
	Fly Lead losses (5m of 1/2")	6.85dB*5m/100m	0.34dB
	Diplexer	0.15dB x2	0.3dB
	Surge arrestor		0.1dB
	Total GSM900 system loss		1.393dB
UMTS2100	Feeder losses (18.5m of 7/8")	5.98dB*15/100	1.106dB
	Fly Lead losses (5m of 1/2")	11.5dB*5m/100m	0.575dB
	Diplexer	0.15dB x2	0.3dB
	ASC		0.4dB
	Surge arrestor		0.1dB
	Total UMTS2100 system loss		2.481dB

Antenna 4:

GSM900	Feeder losses (15m of 7/8")	3.53dB*20m/100m	0.706dB
	Fly Lead losses (5m of 1/2")	6.85dB*5m/100m	0.34dB
	Triplexer	0.25dB x2	0.5dB
	Surge arrestor		0.1dB
	Total GSM900 system loss		1.646dB
DCS1800	Feeder losses (15m of 7/8")	5.04dB*20m/100m	1.008 dB
	Fly Lead losses (5m of 1/2")	10.1dB*5m/100m	0.505dB
	Triplexer	0.25dB x2	0.5dB
	Surge arrestor		0.1dB
	Total GSM900 system loss		2.113dB
UMTS2100	Feeder losses (18.5m of 7/8")	5.98dB*20/100	1.196dB
	Fly Lead losses (5m of 1/2")	11.5dB*5m/100m	0.575dB
	Triplexer	0.25dB x2	0.5dB
	Surge arrestor		0.1dB
	Total UMTS2100 system loss		2.371dB

Antenna 5:

GSM900	Feeder losses (40m of 7/8")	3.53dB*40m/100m	1.412dB
	Fly Lead losses (5m of 1/2")	6.85dB*5m/100m	0.34dB
	Triplexer	0.25dB x2	0.5dB
	Surge arrestor		0.1dB
	Total GSM900 system loss		2.352dB
DCS1800	Feeder losses (40m of 7/8")	5.04dB*15m/100m	2.016dB
	Fly Lead losses (5m of 1/2")	10.1dB*5m/100m	0.505dB
	Triplexer	0.25dB x2	0.5dB
	Surge arrestor		0.1dB
	Total GSM900 system loss		3.121dB
UMTS2100	Feeder losses (40m of 7/8")	5.98dB*15/100	2.392dB
	Fly Lead losses (5m of 1/2")	11.5dB*5m/100m	0.575dB
	Triplexer	0.25dB x2	0.5dB
	Surge arrestor		0.1dB
	Total UMTS2100 system loss		3.567dB

Antenna 6:

DCS1800	Feeder losses (40m of 7/8")	5.04dB*15m/100m	2.268dB
	Fly Lead losses (5m of 1/2")	10.1dB*5m/100m	0.505dB
	Surge arrestor		0.1dB
	Total GSM900 system loss		2.873dB

Antenna 7:

DCS1800	Feeder losses (25m of 7/8")	5.04dB*15m/100m	1.26dB
	Fly Lead losses (5m of 1/2")	10.1dB*5m/100m	0.505dB
	Surge arrestor		0.1dB
	Total GSM900 system loss		1.865dB

Antenna 8:

DCS1800	Feeder losses (40m of 7/8")	5.04dB*25m/100m	1.26dB
	Fly Lead losses (5m of 1/2")	6.56dB*5m/100m	0.505dB
	Surge arrestor		0.1dB
	Total GSM900 system loss		1.865dB

Antenna 9:

DCS1800	Feeder losses (70m of 1 1/4")	2.548dB*15m/100m	1.784dB
	Fly Lead losses (5m of 1/2")	6.56dB*5m/100m	0.328dB
	Surge arrestor		0.1dB
	Total GSM900 system loss		2.212dB

Antenna 10:

DCS1800	Feeder losses (30m of 1 1/4")	2.548dB*15m/100m	1.014dB
	Fly Lead losses (5m of 1/2")	6.56dB*5m/100m	0.328dB
	Surge arrestor		0.1dB
	Total GSM900 system loss		1.442dB

References

- [1] IEC 62232 ed1.0, Determination of RF field strength and SAR in the vicinity of radiocommunication base stations for the purpose of evaluating human exposure. May 2011.
- [2] IXUS version 2.23.104, EMSS Consulting, Technopark, Stellenbosch, 7600, South Africa, <http://www.emssixus.com>.
- [3] *“Guidelines for Limiting Exposure to Time-Varying Electric, Magnetic, and Electromagnetic Fields (up to 300GHz),”* ICNIRP (International Commission on Non-Ionizing Radiation Protection), April 1998.
- [4] ICNIRP Statement on the *“Guidelines for Limiting Exposure to Time-Varying Electric, Magnetic, and Electromagnetic Fields (up to 300GHz),”* *Health Physics*, Volume 97, Number 3, September 2009.
- [5] F.D. du Plessis. Verification of IXUS against IEC 62232 validation examples. Internal Report Number: P02-2011-IXUS-1, 2011. <http://www.emssixus.com>.
- [6] F.D. du Plessis. Field assessment calculation and uncertainty estimation. Internal Report Number: P02-2008-IXUS-1, 2008. <http://www.emssixus.com>.